

Gammabox

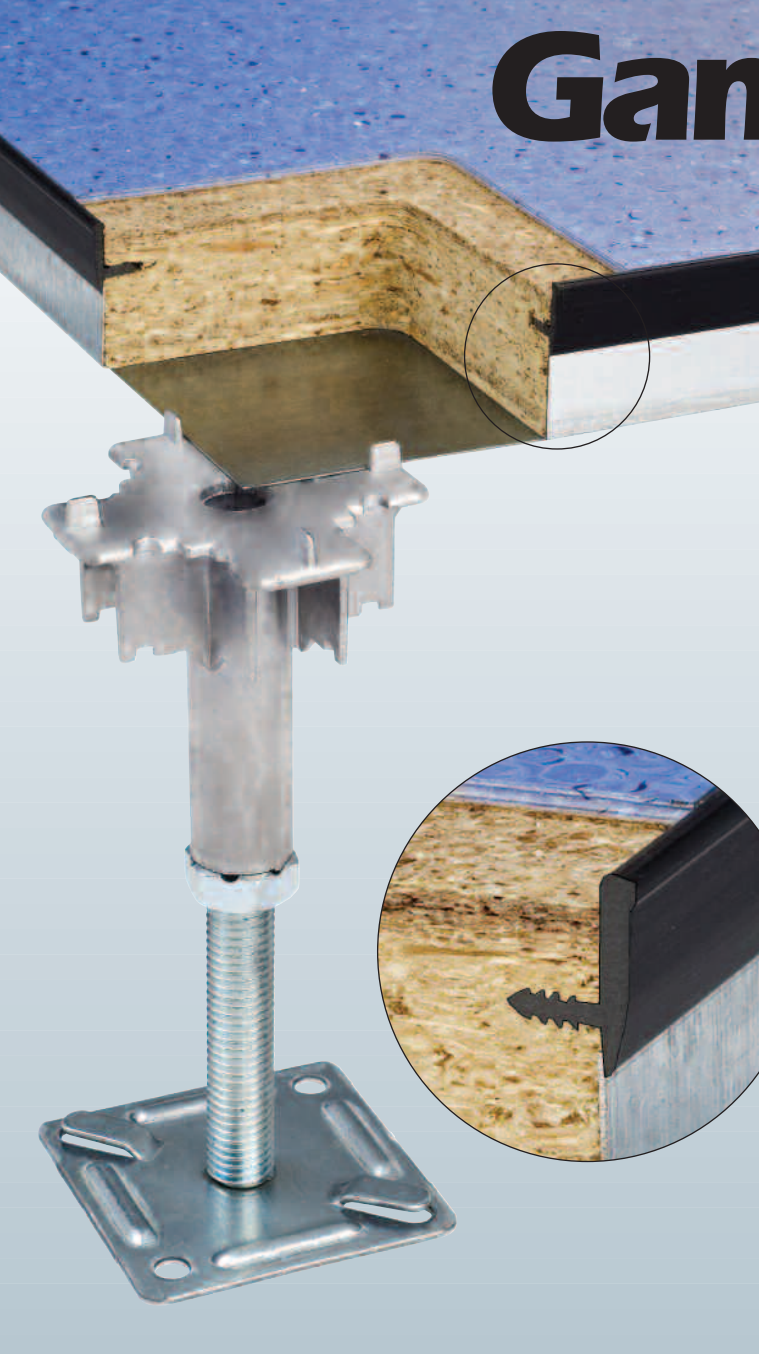

The **Gammabox** panel has been specially designed to meet the requirements of technical, data processing and scientific applications. It is suitable for all the coverings used with access flooring, excepted textile and mineral coverings.

Composition

The **Gammabox** panel is made up as follows :

- A high density resin bonded core, thickness 30 or 38 mm.
- A bottom tray of 0.5 mm thick galvanized steel.
- A perimeter plastic edge trim slotted into the sides of the panel.

Coverings

The **Gammabox** panel is available with the following coverings :

- High pressure laminate
- Vinyl
- Linoleum
- Rubber

Dimensions

Standard size : 600 mm.

Fire classification

The **Gammabox** panel is classed M1 (SNPE report n° 13149-07).

Electrical resistance

It varies from 5×10^5 to 2×10^{12} ohms, depending on the properties of the covering.

Acoustic

The acoustic insulation measured between 2 adjacent rooms, separated by a densely insulated partition, varies from 46 to 51 dBA, depending on the thickness of the panel and the covering (Dn,f,w according to Standard EN ISO 140-12).

Load classes

	Framework	Class	Certificate	
Gammabox 30	Self-supporting	1A (or 2B or 3C)	Nr. 03.10.30.10	NB : A system classed 1A is a system for which the ultimate load is at least 4kN (load class 1). The working load of this system is at least 2 kN, with a safety factor of 2, for a deflection less than 2.5 mm (deflection class A). See tables below for the other classes.
	Stringers 30/15	2A (or 3B or 4C)	Nr. 03.10.30.01	
	Stringers 45/15	5A (or 5B or 5C)	Nr. 03.10.30.05	
Gammabox 38	Self-supporting	3A (or 5B or 5C)	Nr. 04.11.17.03	
	Stringers 30/15	5A (or 6B or 6C)	Nr. 04.11.17.04	

Survey Institute : SOCOTEC CONSULTING.

Load classes according to NF EN 12825 and using safety factor = 2.0.

Load class	Class 1	Class 2	Class 3	Class 4	Class 5	Class 6	Deflection class	Maximum deflection
Ultimate load	>4kN	>6kN	>8kN	>9kN	>10kN	>12kN	A (the most stringent)	2.5 mm
Working load	>2kN	>3kN	>4kN	>4.5kN	>5kN	>6kN	B	3.0 mm
							C (the least stringent)	4.0 mm

Pedestals



Standard pedestal



Pedestal low height

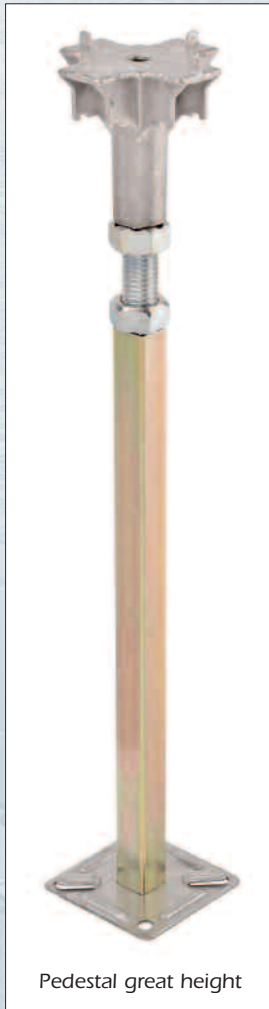

Pedestal great height

The pedestals are made up of :

- a square baseplate of galvanized steel.
- a steel galvanized column welded to the baseplate.
- a die-cast aluminium or steel head, according to the type of pedestal.
- a locking nut for height adjustment.

Standard pedestal

The head has a sufficient length to adjust the height + or - 20 mm. Ridges moulded on the head allow a positive location of the panels.

Pedestal for low finished height

The threaded steel head allows an adjustment of + or - 7 mm. The panels lay directly on a conductive pad. These pedestals allow a minimum finished height of 70 mm.

Pedestal for great finished height (more than 800 mm)

The column is a square hollow section of galvanized steel. The base, the head and the locking nut are the same as for the standard pedestal.

Installation

The pedestals are bonded to the concrete by way of a special adhesive, or may be mechanically fixed.

A device on the baseplate permits a quick and safe fixing of the copper earthing strap.

Stringers



Lockable stringer

Lockable stringers

They are made of galvanized steel . They are designed for location on pedestal heads.

The stringers provide rigidity to the understructure, and stability against lateral strain.

The depth of the section is adapted to the required performances :

- 30 mm deep : type 30/15.
- 45 mm deep : type 45/15.

Special stringers

When pedestals are omitted due to obstructions, i.e. electrical services, air ducting, etc., special bridging stringers may be used.

Within these particular areas, it is admitted that the deflection may be 20% more than for the rest of the raised floor.